



CM - 8 Cablemaster – Rotator Application

DESCRIPTION

The rotator (or swivel) assembly is custom overhead bracketing that allows the *Glendinning* Cablemaster, with one shore power cable, to service both sides of a vessel.

EXAMPLE

For an example, (refer to the following page) the Cablemaster Power Unit is mounted in the engine room on the Starboard side above a container which will store the shore power cable. This is set up (as shown) to send the cable out the Hawse Pipe on the Starboard side of the vessel. When the cable is required on the Port side, the mate will go to the engine room, loosen four mounting studs, rotate the Power Unit 180 degrees, tighten back down the mounting studs and send the cable out through 22 feet of 6" diameter PVC tubing which directs the cable to the Hawse Pipe mounted on the Port side. Control switches for the Cablemaster would be located on the Port and Starboard sides of the vessel and also in the engine room.

ITEMS REQUIRED

For each shore power cable you will require:

- (1) CM-8 Cablemaster

This includes a Power Unit and Hawse Pipe Assembly

- (1) CM-8 Hawse Pipe

- (1) CM-8 Roatator Assembly

This includes the overhead bracket, special machining done on the Power Unit and

- (2) Hatch / Pipe Assemblies

Also NOTE, if 100 feet of shore cable is required (measured from the Hawse Pipe to the plug end) then 120 or 130 feet of cable would probably be needed.

See drawings that follow.



CM - 8 Cablemaster with Rotator Assembly

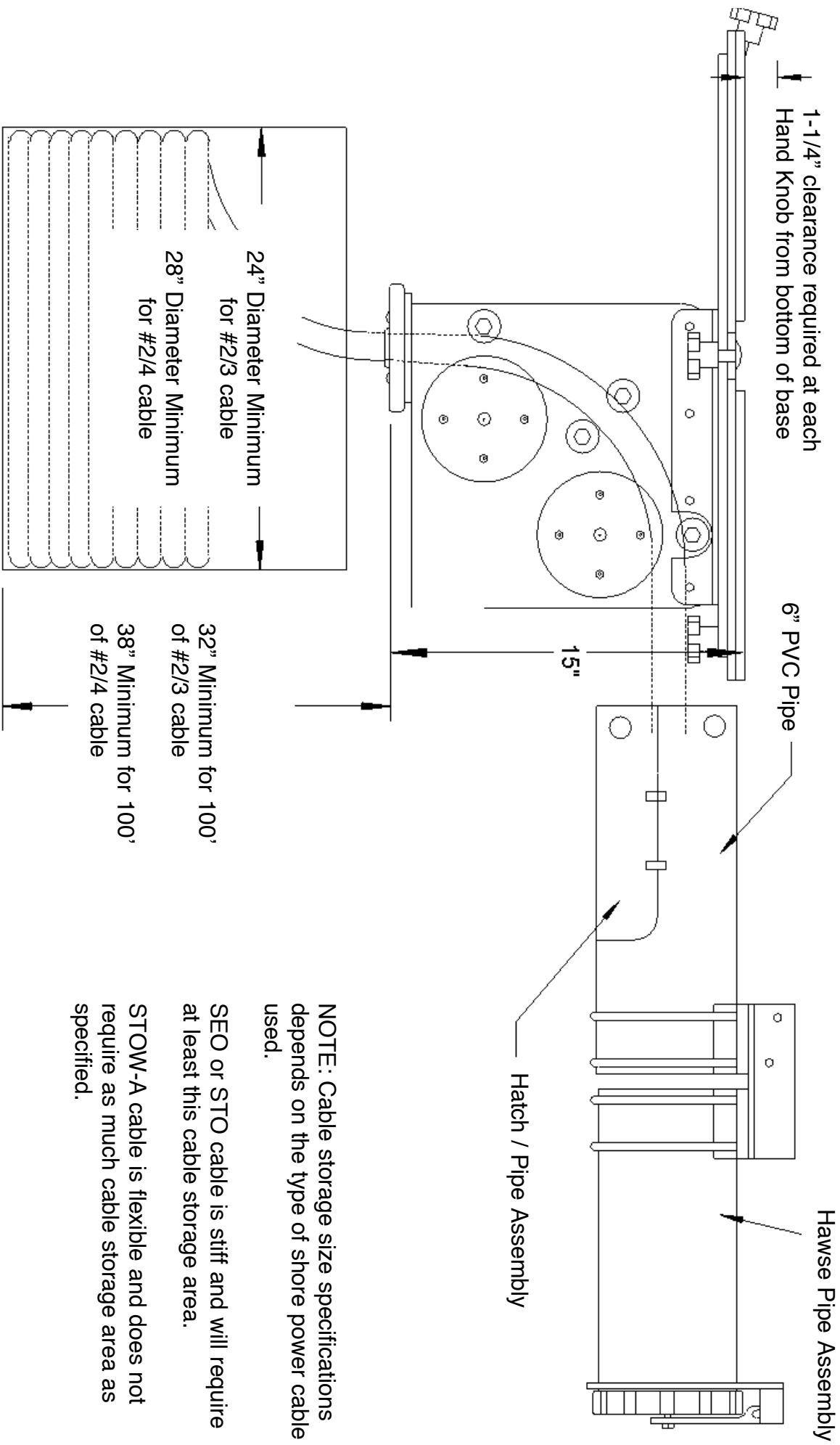

CM - 8 Rotator Assembly

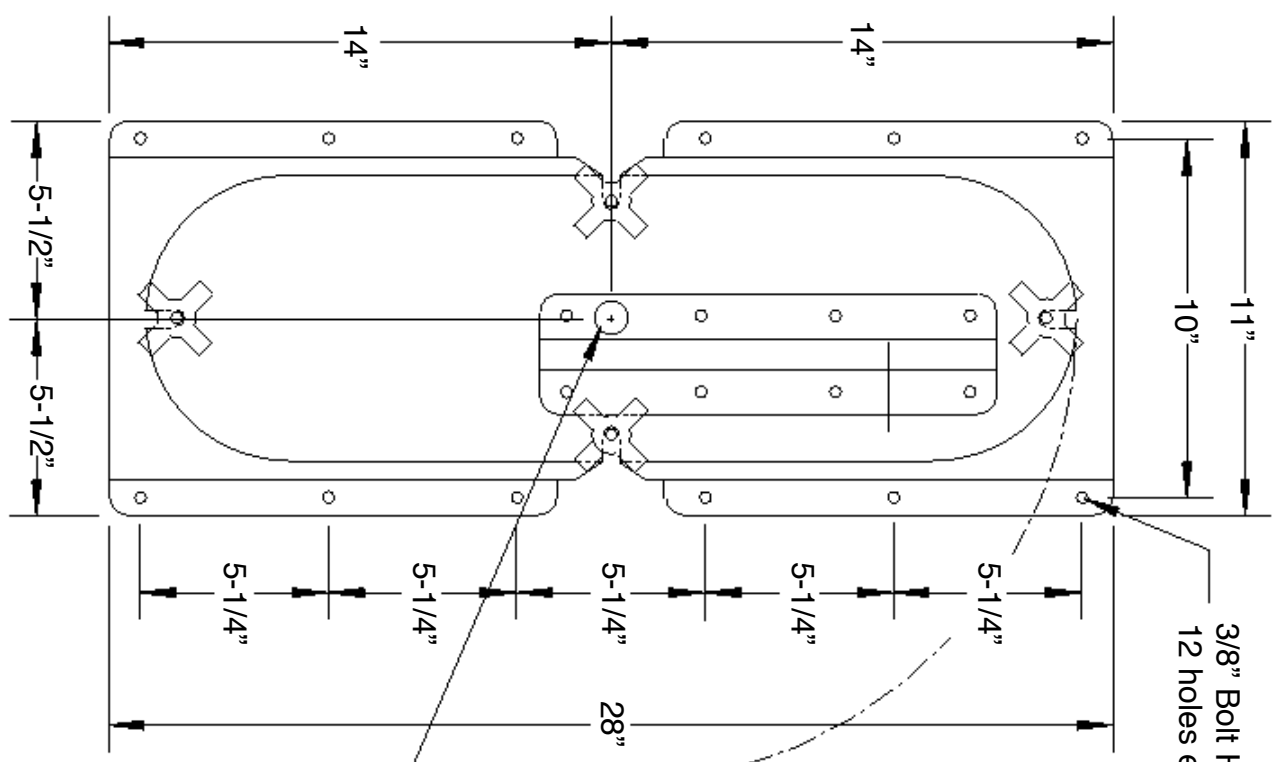
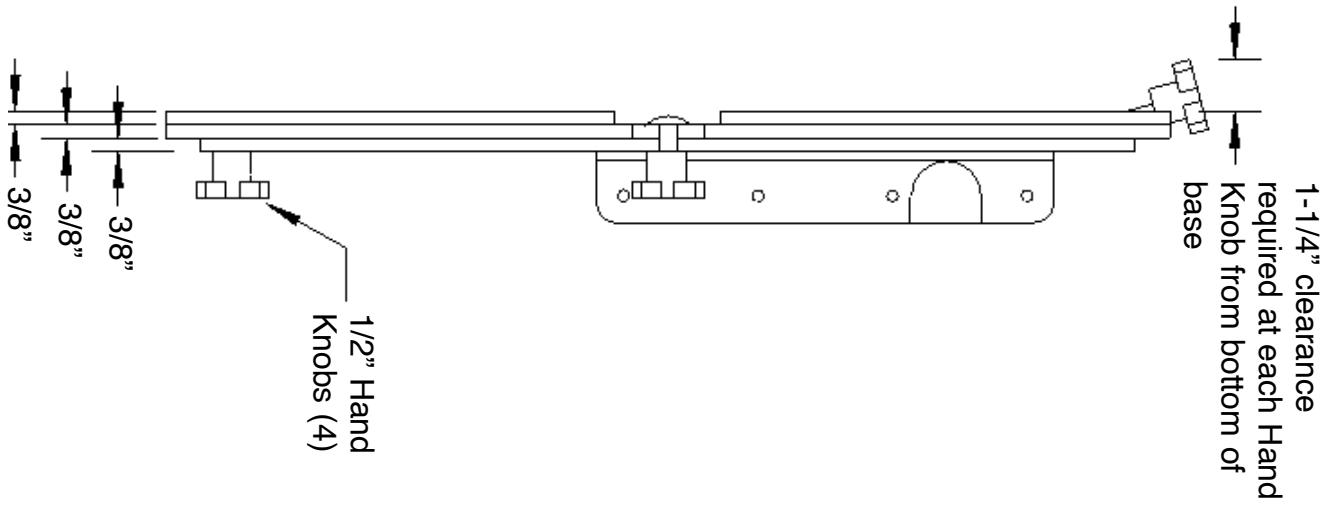

13" Radius from center of plate. This area required on both sides of base for plate to rotate 180 degrees

Center of Plate is where shore cable will drop into the container

- Material: 6061 Aluminum
- Finish: Gold Anodize
- Weight: 24 lbs.

CM - 8 CABLEMASTER with Rotator Assembly

TOP VIEW

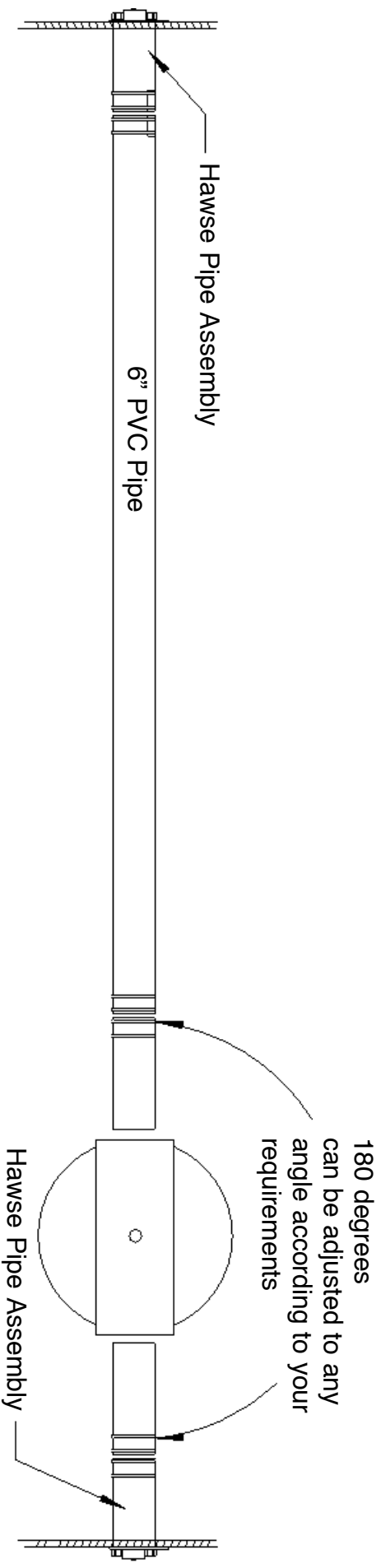

SIDE VIEW

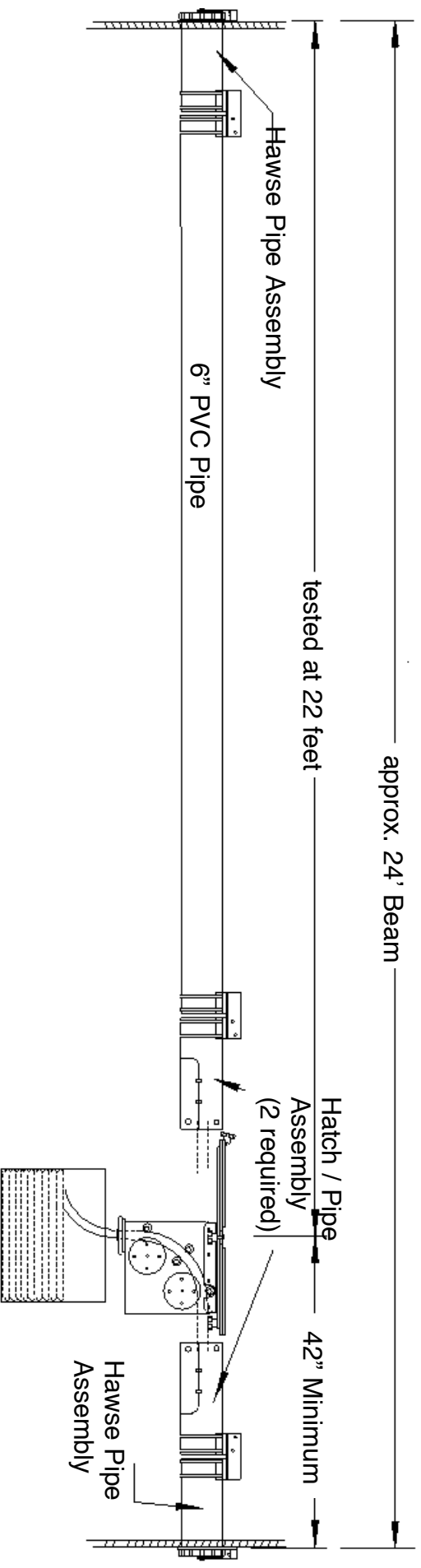

CM - 8 Hawse Pipe

NOTE:

- Hawse Pipe accepts a standard "Pin and Sleeve" type shore side connector
- Exterior of Hawse Pipe may be painted (by the installer) to suite your color preference
- Hawse Pipe Cap has a neoprene gasket to assure a watertight seal

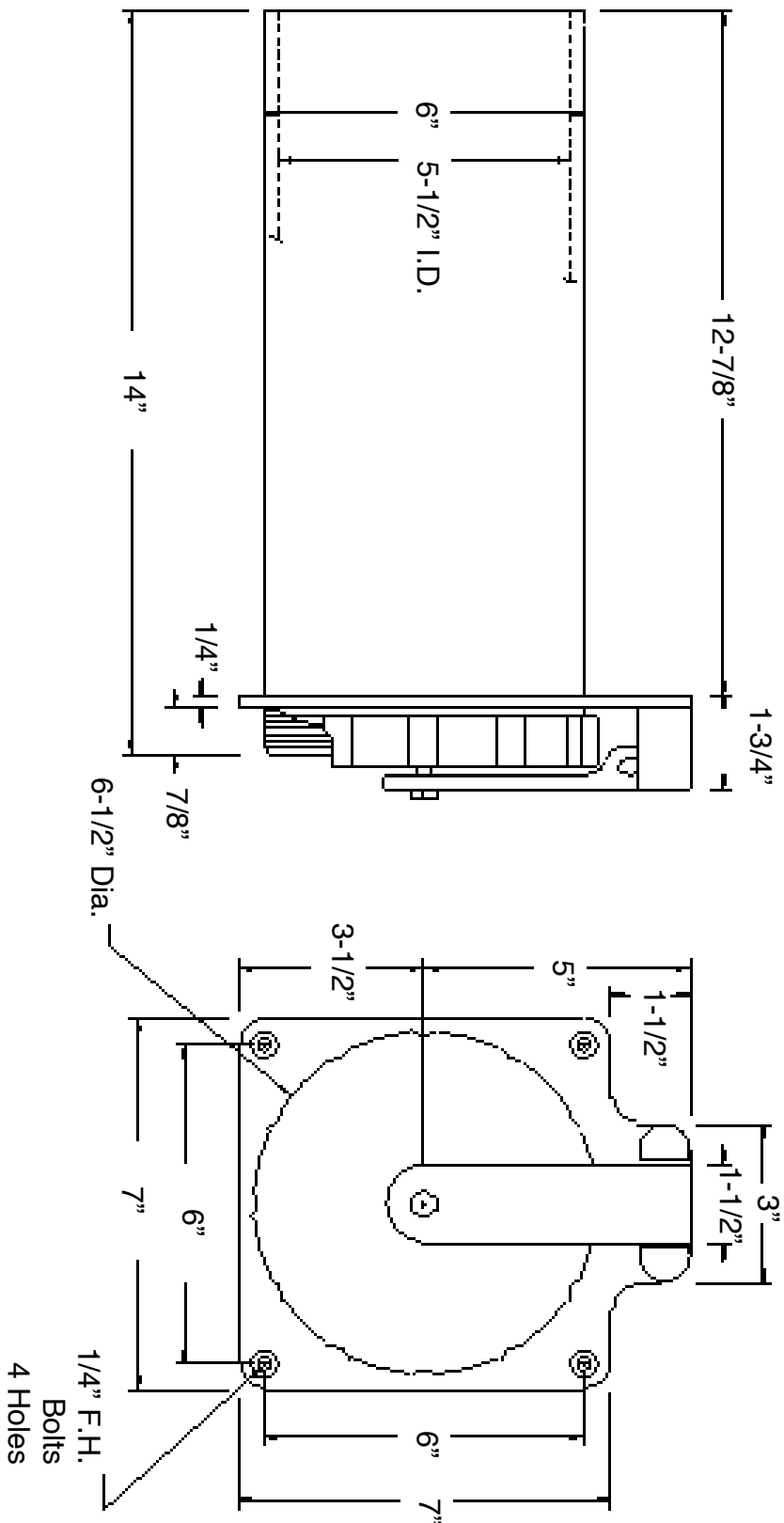

MATERIAL: 6061 Aluminum

FINISH: Yellow Anodize

CM - 8 Cablemaster

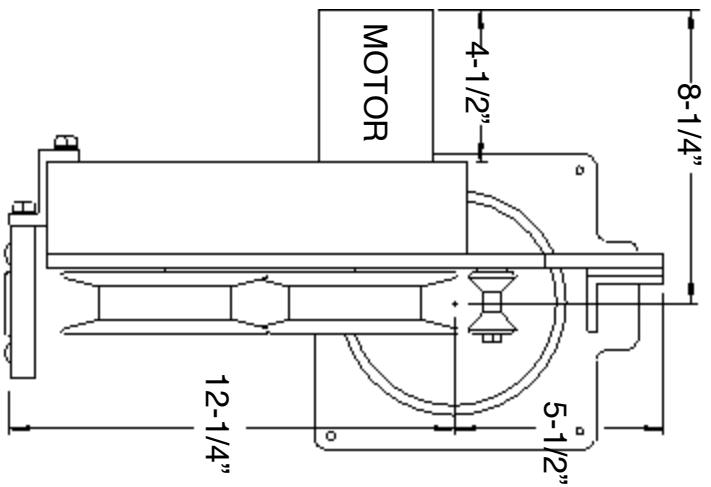

WEIGHT:

- CM8 Hawse Pipe 12 lbs.
- CM8 Power Unit 40 lbs.

MATERIAL:

6061 Aluminum

FINISH:

Gold Anodize

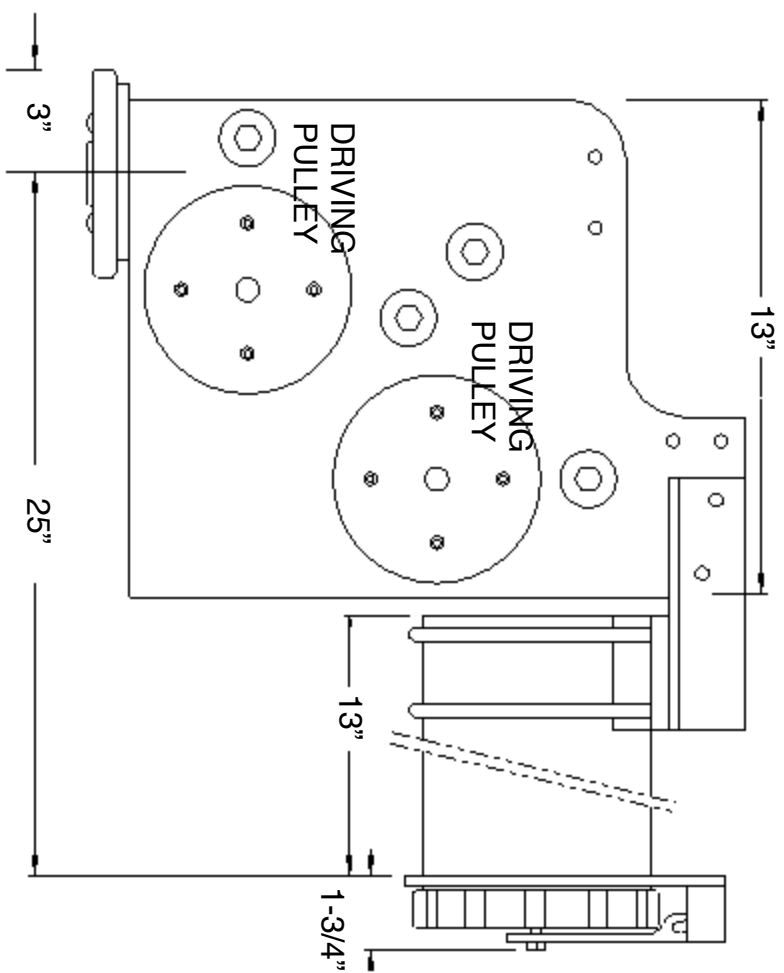

Minimum distance from hull to center of storage space - may be extended.

NOTE:

See Manual for cable storage area specifications.